

3203

# 32 Series

- 55 HP
- Air Cooled
- 2-Stroke
- Ultimate power to weight ratio
- Ideal for light aviation, hovercraft, gyro or helicopters



## DESCRIPTION

**Ideally suited for light and ultralight aviation.**

The 32 Series air cooled two-stroke engines offer the highest power-to-weight ratios available in the 55-horsepower market.

Ideally suited for use in light and ultralight aviation, hovercraft, gyro and helicopters and all applications where weight could be an issue.

The most powerful air cooled 2-stroke engine we've developed, the 32 Series offers a time between overhauls of 1000 hours.



3203

# 32 Series



## TECHNICAL SPECIFICATION:

<b>TYPE:</b>	<b>Two cylinder two stroke</b> (inline)	<b>WEIGHT:</b>	<b>31 kg</b> (68,4 lb)
<b>DISPLACEMENT:</b>	<b>625 cm<sup>3</sup></b> (38,1 in <sup>3</sup> )	<b>LENGTH:</b>	<b>377 mm</b> (14.84 in)
<b>STROKE:</b>	<b>69 mm</b> (2,72 in)	<b>WIDTH:</b>	<b>587 mm</b> (23.11 in)
<b>BORE:</b>	<b>76 mm</b> (2,99 in)	<b>HEIGHT:</b>	<b>383 mm</b> (15.07 in)
<b>MAX. PERFORMANCE:</b>	<b>40,4 kW (55 HP)</b> at 5500 rpm According to DIN 70020	<b>STARTING DEVICE:</b>	<b>Recoil starter</b>
<b>MAX. TORQUE:</b>	<b>72 Nm (52,8 ft.lb)</b> at 5000 rpm	<b>RUNNING DIRECTION:</b>	<b>Counter-clockwise</b> , view to output shaft
<b>CARBURATION:</b>	<b>2x slide carburetor</b> (Dell Orto) or <b>fuel injector</b>	<b>COOLING:</b>	<b>Fan cooling</b>
<b>FUEL MIXTURE:</b>	<b>Mixture 1:50</b> , 2-stroke-oil, fuel min. 95 octane (RON) <b>Mixture 1:80-100</b> with BLUEMAX 2-stroke-oil, fuel min. 95 octane	<b>IGNITION SYSTEM:</b>	<b>CDI</b>

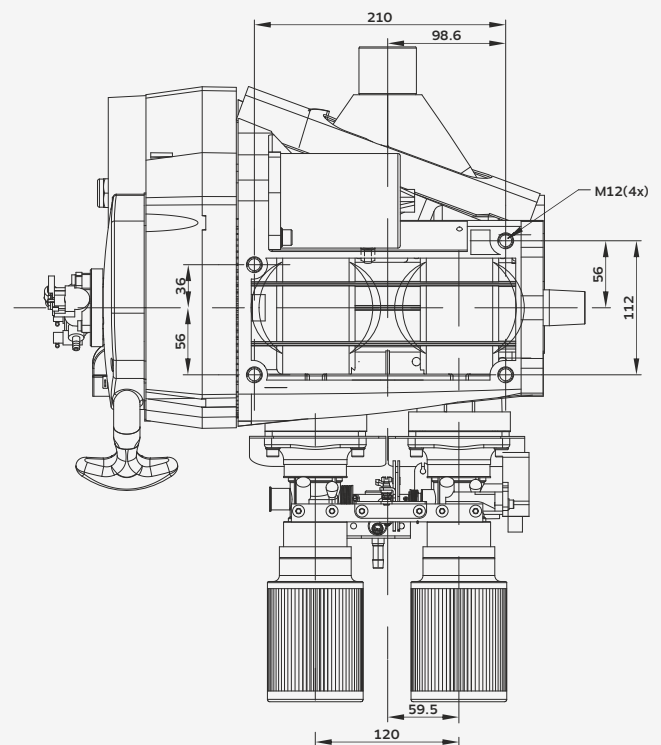
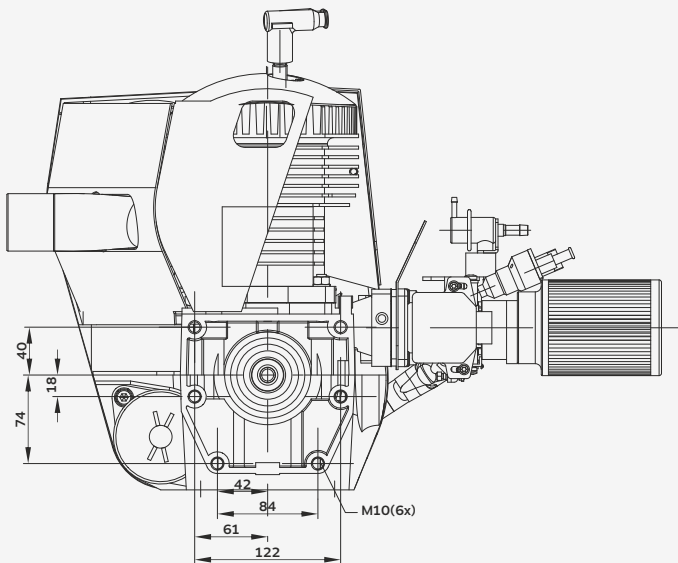

## OPTIONS

- Dual ignition
- Fuel injection
- Belt reduction **G 27** (1:1.8/1:2.0)
- Gear box **G 50** (1:2,16/1:2,29/1:2,59/1:3,16/1:3,65)
- Electric starter
- Separate lubrication

**Hirth is a registered trademark of Hirth Engine GmbH. All rights reserved. This is not a certificated aircraft engine!** It has not received the safety and durability testings specified by aircraft standards. It is only for use in uncertificated experimental aircraft or vehicles when there is no risk for the safety due to an engine failure. Never fly the aircraft equipped with this engine in circumstances or in areas, in weather-conditions or in altitudes where you have no chance for successful landing after an engine failure. The user is taking all risk resulting from the use of this engine and he is aware of the possibility of sudden functional disturbances. [www.hirthengines.com](http://www.hirthengines.com)

**Northwest UAV**  
A GLOBAL COMPANY

**AUTHORIZED HIRTH ENGINE DISTRIBUTOR FOR NORTH AND CENTRAL AMERICA**  
11160 SW Durham Lane, Suite 1 | McMinnville, OR 97128  
Office: 503.434.6845 | Fax: 503.217.6080 | [www.nwuav.com](http://www.nwuav.com)



The materials contained in this brochure are provided for information only, "as is" without any warranties, express or implied, including warranties of merchantability, fitness of purpose and non-infringement of third-party intellectual property. While every effort is made to ensure that the information and specifications are accurate, the scope of information is limited by nature. NWUAV Propulsion Systems reserves the right to make changes to the Products described in the Product Brochure at any time, without notice. The application of our products is dependent upon the operating mission, environmental conditions, loads and other factors; none of which can be ascertained by this brochure. Any technical advice or information gleaned from this Product Brochure is given in good faith and without charge, and said advice and information is provided by NWUAV Propulsion Systems without assumption of liability or obligation. This brochure and the information it contains is the work product of NWUAV Propulsion Systems ("NWUAV"). All title, ownership rights and intellectual property rights in and relating to this brochure is owned by NWUAV or used by NWUAV through pre-authorization by third parties and cannot be used without its express prior written permission.