

**“tough tech for tough environments“**

## **PA-R-440-7 servo-actuator**

### **data sheet - technical specifications**

#### **Supply data:**

Operating voltage: 18 – 32 V DC  
Operating voltage typical: 24 V DC  
Standby current: 40mA

#### **Input signal:**

PWM signal, TTL level (standard)  
PWM signal, differential (RS485 transceiver) (optional)  
or RS485 data protocol (optional)

#### **PWM parameter:**

Frame rate: 2,6 - 1000ms  
Valid pulse length: 1,0 - 2,0ms  
left / center / right: 1,0ms - 1,5ms - 2,0ms

#### **Position feedback:**

analog, differential: 0-5V  
Scale factor: 27.78 mV/deg

#### **Performance data:**

Maximum torque: > 35 Nm (> 26 lbf ft)  
Rated torque<sup>\*\*</sup>: 20 Nm (14,8 lbf ft)  
Speed at rated torque: 70°/sec @ 28 V DC, 55°/sec. @ 24 V DC  
No load speed: 105°/sec @ 28 V DC, 90°/sec. @ 24 V DC  
Gear train backlash: < 0,5°  
Travel angle: ± 90° (-5%)  
Maximum travel angle (optional): ± 170° (-5%)  
Slip clutch release momentum: 35 Nm (> 26 lbf ft) +20%  
Peak current - short time: 16A  
Stall current - continuous: 2A (limited)  
Minimum detectable signal step: max 0,25µsec. (adjustable)  
Weight: 1500gr. (3,3lb)

<sup>\*\*</sup>according to specifications of Pegasus Actuators GmbH  
(please inquire the test-specifications)

#### **Environmental data:**

Axial load on output shaft: < 150N  
Operating temperature: -40°C - +70°C (-40°F - +158°F)  
Storage temperature: -40°C - +80°C (-40°F - +176°F)

#### **Environmental specifications:**

Vibration test: Please inquire test documentation  
Shock test: Please inquire test documentation  
Protection class: IP67



DISTRIBUTOR

  
**Northwest UAV**  
A GLOBAL COMPANY

11160 SW Durham Lane, Suite 1 | McMinnville, OR 97128 USA

+1 503.434.6845  
+1 503.217.6080  
customerservice@nwuav.com  
[www.nwuav.com](http://www.nwuav.com)

**“tough tech for tough environments“**

## **PA-R-440-7 servo-actuator**



### **data sheet - technical specifications**

#### **Main components:**

**Case:** IP67 water and dust protected with solid vertical and horizontal fixation.  
material: CNC machined aluminum, bead blasted and anodized.

**Gear train:** hardened steel spur gear type, 10 roller bearings, with PA-SC gear train protection system, output shaft with defined alignment..

**Motor:** Neodym-magnet BLDC motor, double ball raced.

**Amplifier:** digital positioning controller

#### **Sensor travel angle:**

mechanical: 360° (no end stops)

electrical - (standard):  $\pm 45^\circ$

electrical - (optional):  $\pm 160^\circ$

#### **Actuator connector:**

Glenair Series 801 Mighty Mouse connector (standard)

Glenair Series 28 HiPer-D Combo connector (optional)

**“tough tech for tough environments“**

# PA-R-440-7 servo-actuator

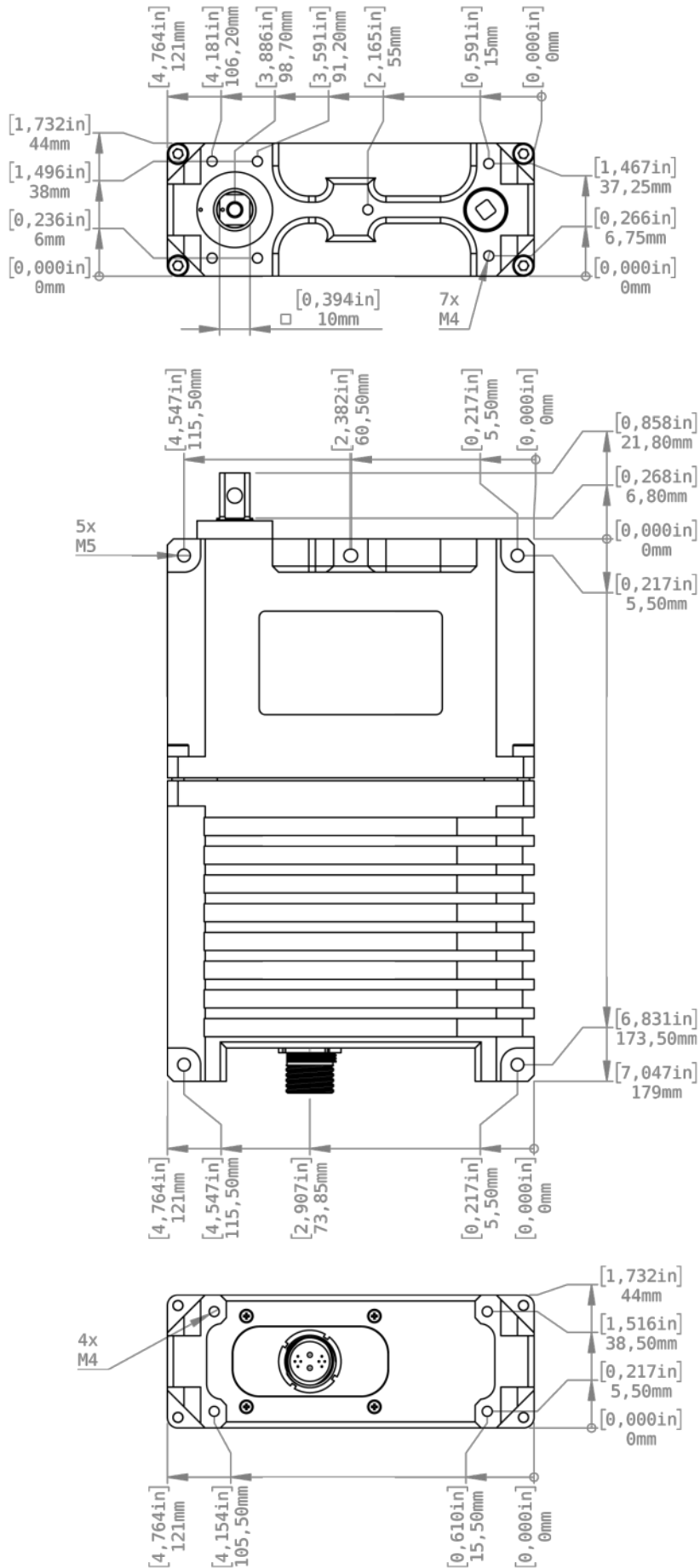

“tough tech for tough environments“

PA-R-440-7 servo-actuator



PA-R-440-7-C-24-X-XXX-XX  
24V

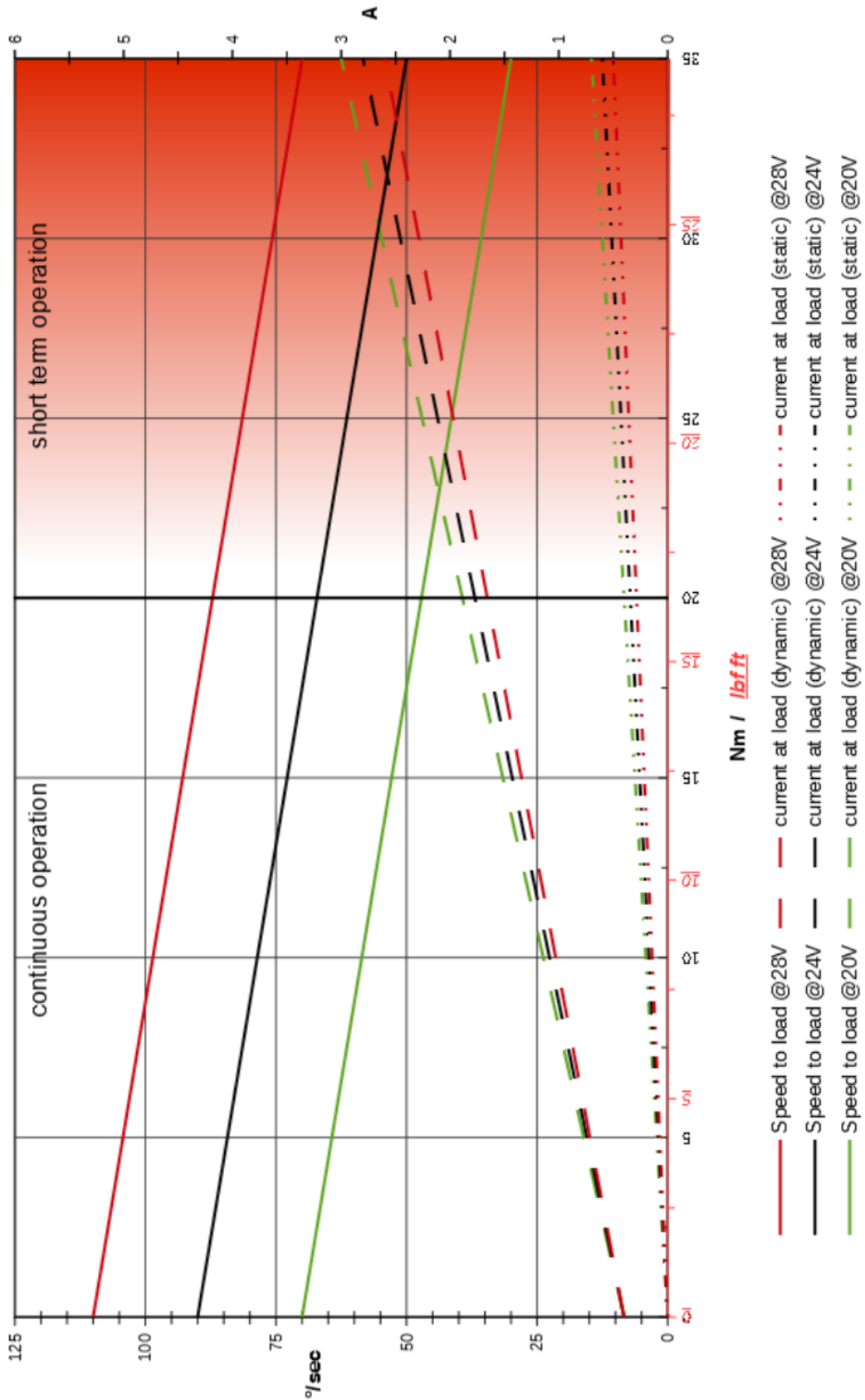

! The overload protection limits the performance of the actuator during overload conditions. !