



Pegasus

Actuators GmbH

PA-RR-340-7-C-24-C-315-00 - Datasheet

Ersteller	Author	Mark Kuhmann			
Datum	Date	2019-06-11			
Kontakt	Contact	m.kuhmann@pegasus-actuators.com			
Version	Revision	A01			
Benachrichtigung			Notifications		
Name	Name	Firma	Company	Kontakt	Contact
Gegenstand des Dokuments			Subject of the document		
Dieses Dokument beschreibt die technischen Eigenschaften des Redundanten Aktuators PA-RR-340-7-C-24-C-315-00.					
This document describes the technical specifications of the redundant Actuator PA-RR-340-7-C-24-C-315-00.					
Verwendungszweck des Dokuments			Purpose of the document		
Das Dokument ist für die offizielle Dokumentation / Werbe und Verkaufszwecke.					
The document is for official Publication / Advertising and sales purpose.					

 <p>DISTRIBUTOR</p> <p>Northwest UAV A GLOBAL COMPANY</p>	☎ +1 503.434.6845
	📠 +1 503.217.6080 customerservice@nwuav.com www.nwuav.com
11160 SW Durham Lane, Suite 1 McMinnville, OR 97128 USA	

Title: RR340-7 type Actuators - Datasheet	Document: PR-DS_Datasheet-RR340-7- type-A01_2019-06-11	revision: A01	 Pegasus Actuators GmbH
		date: 11. June 2019	
		page: 2 /9	

PA-RR-340-7-C-24-C-315-00



Title: RR340-7 type Actuators - Datasheet	Document: PR-DS_Datasheet-RR340-7- type-A01_2019-06-11	revision: A01	
		date: 11. June 2019	
		page: 3 /9	

Content

General Description.....	4
Redundancy Architecture.....	4
Operating Data.....	5
Supply data.....	5
Input signal:.....	5
Travel angle:.....	5
Performance data.....	5
Environmental data.....	5
Environmental specifications.....	5
Product features.....	6
Dimensions.....	6
Connector.....	6
Pin Assignment.....	6
RS485 Interface Description.....	6
Performance Graph 24VDC.....	7
Dimension - Drawing.....	8
Order Code.....	9

Title: RR340-7 type Actuators - Datasheet	Document: PR-DS_Datasheet-RR340-7- type-A01_2019-06-11	revision: A01	
		date: 11. June 2019	
		page: 4 /9	

General Description

Pegasus redundant servo actuators have been developed for applications that require extraordinary operating reliability. The actuator's two channel design allows for continuous operation even after a single point failure has occurred.

Redundancy Architecture

The actuator hardware consists of the following:

Multiple master control units allow for a majority decision, 2 independent servo controllers each controlling one brushless motor and 3 contact-less position angle sensors in order to detect and rectify an incorrect output shaft position signal. During standard mode the actuator exchanges signals thru both actuator channels.

In standard mode motor no. 1 and its power stage unit are working, meaning that the motor no. 2 and its power stage unit will only be engaged after no.1 unit has failed.

The actuator performance is not negatively affected after a motor/ power stage failure.

An example for a single point failure management: in case of a defective motor, the multiple master controllers immediately recognize that the actuator did not reach the desired position in time. The back up motor/ servo controller unit will be switched on without requiring the assistance of the AP. In principle all possible single point failures are handled accordingly.

Another example: in case of a broken signal cable, the multiple master controllers will diagnose a missing or invalid signal and switch to the other channel. In case of two different but valid signals, the master-controllers will stay with the original communication channel.

Title: RR340-7 type Actuators - Datasheet	Document: PR-DS_Datasheet-RR340-7- type-A01_2019-06-11	revision: A01	
		date: 11. June 2019	
		page: 5 /9	

Operating Data

Supply data

Operating voltage:	18 – 32 V DC
Operating voltage typical:	24 V DC
Standby current:	250mA

Input signal:

Redundant RS485 data protocol

Travel angle:

Standard travel angle:	315°, ($\pm 157,5^\circ$) -5%
------------------------	---------------------------------

Performance data

Maximum torque:	> 1800 Ncm (> 2540 oz-in)
Rated torque ² :	850 Ncm (1200 oz-in)
Speed at rated torque:	140°/sec
No load speed:	200°/sec
Slip clutch release momentum:	>1800 Ncm (> 2540 oz-in) +20%
Actuator Peak current short time:	6,5 A
Gear train backlash:	< 0,5°

² according to specifications of Pegasus Actuators GmbH
(please inquire the test-specifications)

Environmental data

Operating temperature:	-40°C - +70°C (-40°F - +158°F)
Storage temperature:	-40°C - +85°C (-40°F - +185°F)

Environmental specifications

Vibration test:	Please inquire test documentation
Shock test:	Please inquire test documentation
Protection class:	IP67
Environmental Conditions and Tests	D0-160 F (RTCA)

Title: RR340-7 type Actuators - Datasheet	Document: PR-DS_Datasheet-RR340-7- type-A01_2019-06-11	revision: A01	
		date: 11. June 2019	
		page: 6 /9	

Product features

Redundant PA-ME³ magnetic deflection angle sensor
 Dual brushless motors
 Dual servo controller PCB
 Dual Glenair Mighty Mouse Series 801, 10-pin connector
 Single Point Failure redundancy architecture
 Oil lubricated gear-box
 Unparalleled anti flutter circuit
 Enhanced positioning resolution
 Inbuilt (switchable) termination resistor
 Inbuilt safeguarding against Motor overcurrent
 Inbuilt power supply filter
 Enhanced feedback signal resolution

Dimensions

Case Dimensions:	140 x 186 x 34 mm 5,51 x 7,32 x 1,34 in
Weight:	1,1Kg (2,43 lb)

Connector

Glenair Series 801 MightyMouse: 801-011-07NF10-202PA
 Mating connector: Glenair Series 801-007 or 801-008 with shell size 10-202 and Key position A

Pin Assignment

1	Signal A
2	Signal B
3	
4	
5	Power - (GND)
6	Power + (VCC)
7	Signal A- output ¹
8	Signal B - output ¹
9	
10	

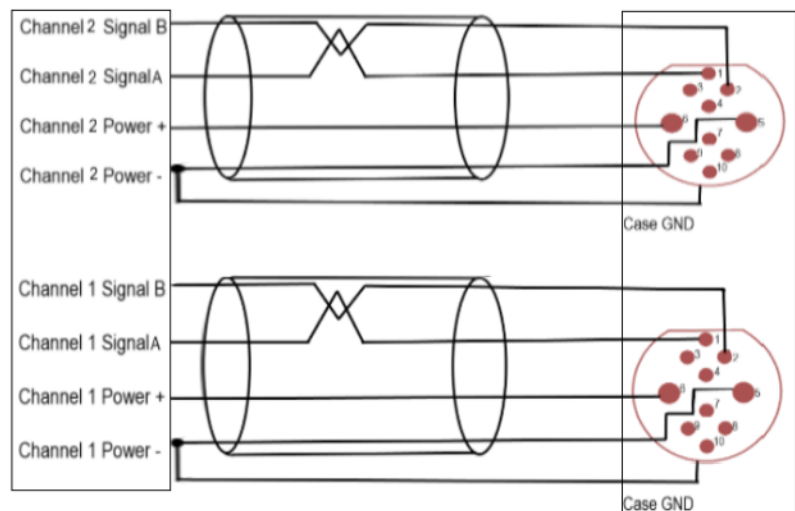



¹: pin 7 and pin 8 can be connected optional for daisy chain wiring

RS485 Interface Description

Baud-Rate	115200 bit/sec. ±1,357%
Resolution	< 0,022°

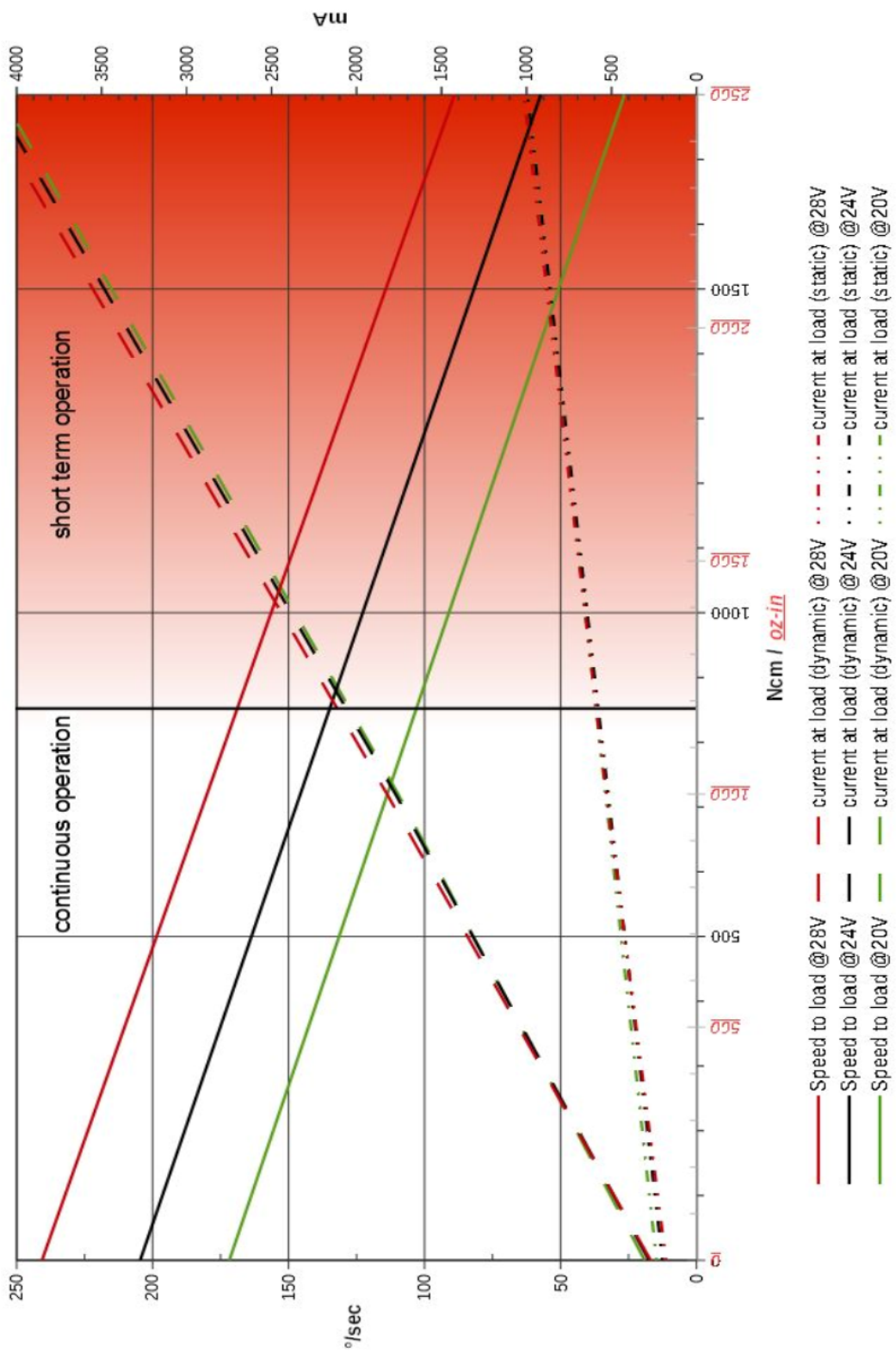
Performance Graph 24VDC



Title: RR340-7 type Actuators - Datasheet	Document: PR-DS_Datasheet-RR340-7- type-A01_2019-06-11	revision: A01	
		date: 11. June 2019	
		page: 8 / 9	

Dimension - Drawing

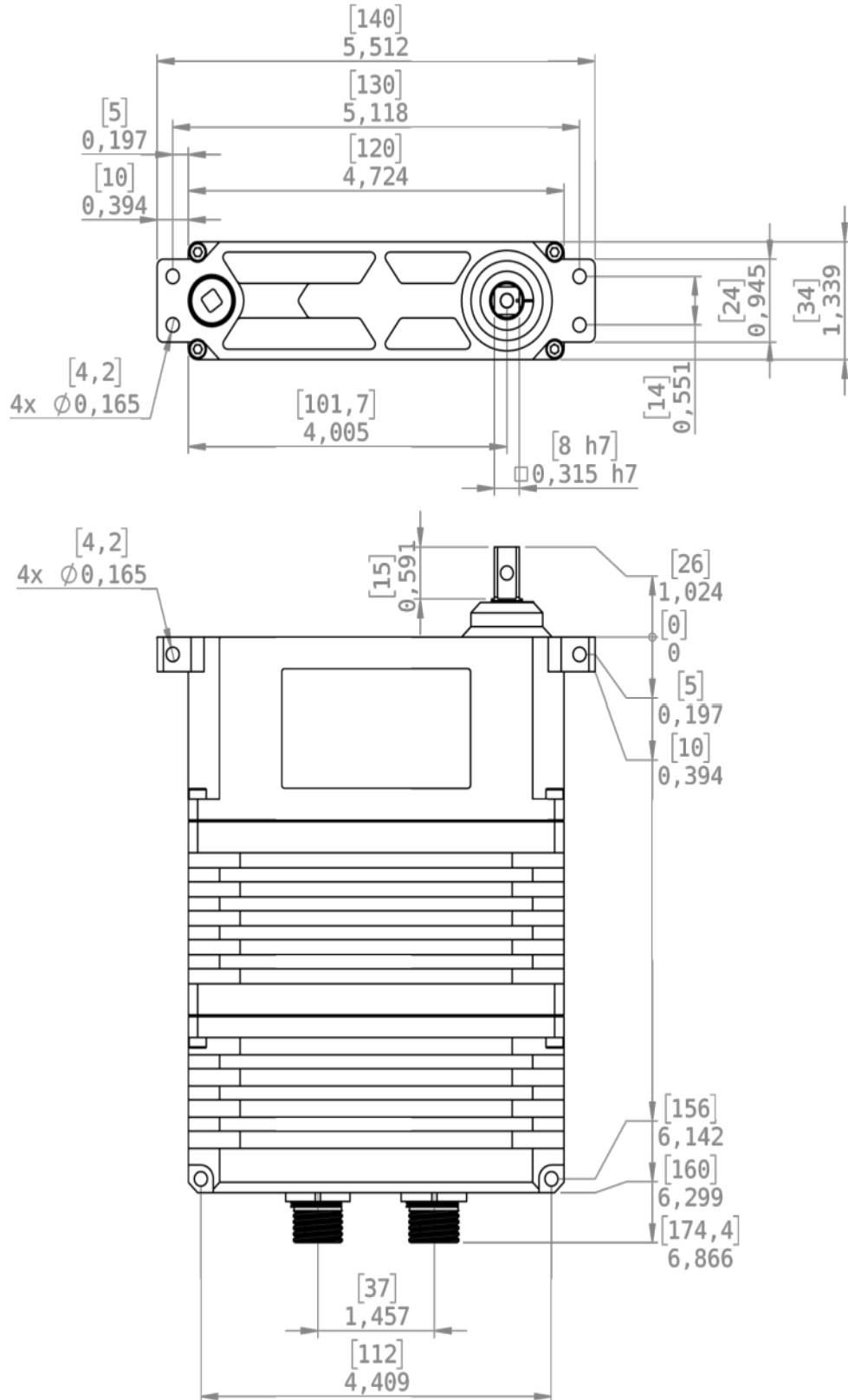

Dimensions are in: [mm]
inch

Title: RR340-7 type Actuators - Datasheet	Document: PR-DS_Datasheet-RR340-7- type-A01_2019-06-11	revision: A01	
		date: 11. June 2019	
		page: 9 /9	

Order Code

PA - RR - 340 - X - X - XX - X - XXX - XX

Actuator type: redundant/rotary/34,0mm wide

torque index: 9

output-shaft: C PA-SC

operating 12 8 to 16 VDC operating range

Voltage: 24 18 to 32 VDC operating range ¹

Signal type: C Redundant RS485 data protocol

Travel angle: 315 315° travel angle

Revision 00 Glenair series 801 connector

index:

¹: standard